

**Bollard**

*Dissuasore di sosta*

DF 25-82

# X Rubber CITY

CITY is a line of rubber products for urban furniture and street applications. The products are of high quality and performance, are resistant to atmospheric agents, do not fade and are long lasting. They are easily installed permanently and/or removable for maintenance. Available in various colour either painted (non-toxic water paint) or mass coloured.

CITY è la linea di prodotti in gomma per l'arredo urbano e le applicazioni stradali. I prodotti sono di elevata qualità e prestazioni, sono resistenti agli agenti atmosferici, non sbiadiscono ed hanno una lunga durata. Si installano facilmente in modo permanente, e/o possono essere rimossi per manutenzioni. Sono disponibili in vari colori sia verniciati (vernice ad acqua) sia colorati in massa.



## Bollard Dissuasore di sosta DF 25-82

Impact absorbing Bollard produced by moulding of a selected mix of rubber granulates obtained from tyre recycling, agglomerated with polyurethane binders.

Dissuasore di sosta ad assorbimento di impatto realizzato mediante stampaggio di miscele selezionate di granulati di gomma ottenuti dal riciclaggio dei pneumatici, agglomerati con leganti poliuretanic.



### TECHNICAL FEATURES CARATTERISTICHE TECNICHE

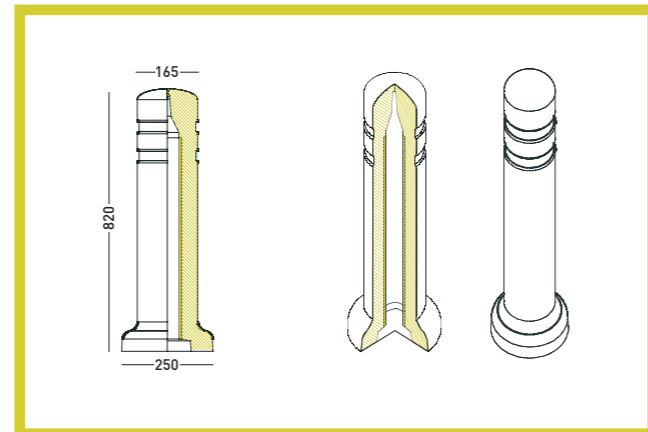

HEIGHT/ALTEZZA	820 mm
MAX WIDTH/LARGHEZZA MASSIMA	250 mm
WEIGHT/PESO	15 Kg +/- 10%

**COLOURS/COLORI**  
Natural black. Colours: various painted colours (non-toxic water paint) or mass coloured.  
Nero naturale. Colori: verniciato (vernice ad acqua) oppure pigmentato in massa.

**DETAILS/DETTAGLI**  
With two horizontal grooves to be equipped with reflective strips.  
Dotato di due scanalature orizzontali per l'inserimento di pellicole rifrangenti.



**INTENDED USE**  
Temporary or permanent installation to mark pedestrian areas, crosswalks, parking areas, cycle paths, etc.

**APPLICAZIONI**  
Delimitazioni permanenti o temporanee di spazi vietati alla sosta, demarcazione traffico pedonale, ciclabile e veicolare, ecc.



**ATTACHMENTS**  
1. Polyethylene pipe to be buried in concrete;  
2. Iron anchor plate, screw and screw anchor.

**ACCESSORI A RICHIESTA**  
1. Tubo in polietilene da affogare nel calcestruzzo.  
2. Piastra di fissaggio in ferro, viti e tasselli a espansione.



**INSTALLATION**  
Line up the bollards; drill the pavement; put the anchor plate, screws anchor or the chemical fixing, the screws, tighten them; set off the bollards, screw the bollard to the anchor plate.

**POSA**  
Allineare i dissuasori; forare la pavimentazione; posizionare la piastra di fissaggio, il tassello o il collante, le viti e serrare; posizionare il dissuasore e fissarlo con la vite alla piastra.

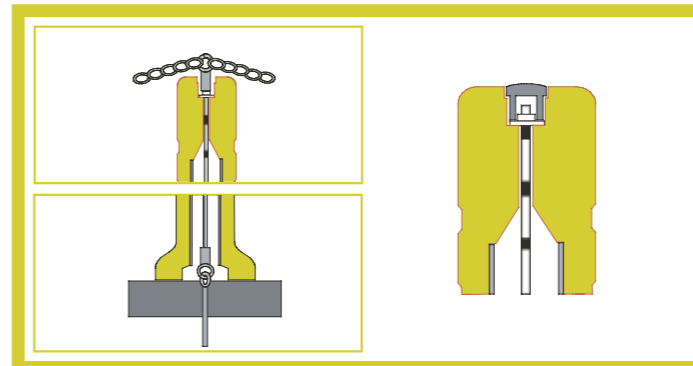
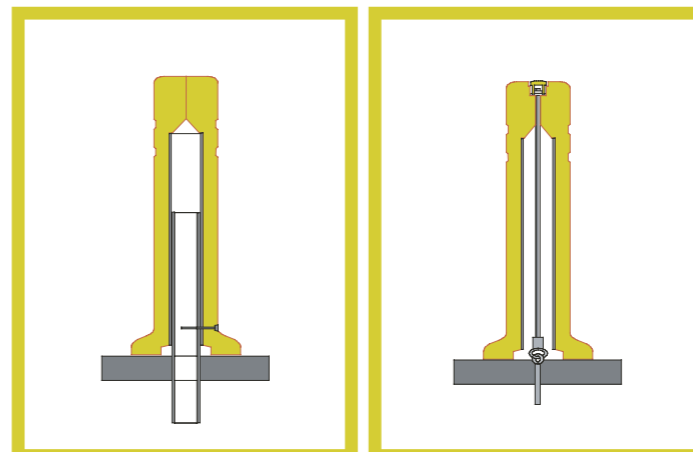

**CERTIFICATION**  
CERTIFICAZIONI



**CYCLE LANES**  
PISTE CICLABILI



**SCHOOLS**  
SCUOLE



**PUBLIC GARDENS**  
GIARDINI PUBBLICI



**FLOWERBEDS**  
AIUOLE



**RESTRICTED TRAFFIC ZONES**  
AREE TRAFFICO LIMITATO



**OUTDOOR AND MULTILEVEL PARKING**  
PARCHEGGI SCOPERTI E MULTIPIANO



**PLAYGROUND AREAS**  
AREE GIOCO



**PEDESTRIAN LINES**  
CORSIE PEDONALI



**DRIVEWAYS**  
ACCESSO VIALETTI PRIVATI / PASSI CARRAI



**RAILWAY STATIONS**  
STAZIONI FERROVIARIE



**BUS STATIONS**  
STAZIONI AUTOBUS

**PLUS**



**ANTISHOK**  
ANTITRAUMA



**ECO-SUSTAINABLE**  
ECO-SOSTENIBILI



**EASY TO INSTALL**  
FACILI DA INSTALLARE



**CERTIFICATED**  
CERTIFICATI



**RUBBER PRODUCTS FOR URBAN FURNITURE AND STREET APPLICATIONS**  
*PRODOTTI IN GOMMA PER LA VIABILITÀ STRADALE E L'ARREDO URBANO*



Rubber  
CITY

**CITY IS A RUBBER X PRODUCT**  
*CITY È UN PRODOTTO RUBBER X*



**INFO@RUBBERX.IT**  
**WWW.RUBBERX.IT**