



**Mini New-Jersey-P Curb**  
*Cordolo Mini New-Jersey-P*  
CF 14-12



# X Rubber CITY

CITY is a line of rubber products for urban furniture and street applications. The products are of high quality and performance, are resistant to atmospheric agents, do not fade and are long lasting. They are easily installed permanently and/or removable for maintenance. Available in various colour either painted (non-toxic water paint) or mass coloured.

CITY è la linea di prodotti in gomma per l'arredo urbano e le applicazioni stradali. I prodotti sono di elevata qualità e prestazioni, sono resistenti agli agenti atmosferici, non sbiadiscono ed hanno una lunga durata. Si installano facilmente in modo permanente, e/o possono essere rimossi per manutenzioni. Sono disponibili in vari colori sia verniciati (vernice ad acqua) sia colorati in massa.



## Mini New-Jersey-P Curb Cordolo Mini New-Jersey-P CF 14-12

Curb produced by moulding of a selected mix of rubber granulates obtained from tyre recycling, agglomerated with polyurethane binders.

Cordolo realizzato mediante stampaggio di miscele selezionate di granulati di gomma ottenuti dal riciclaggio dei pneumatici, agglomerati con leganti poliuretanic.



### TECHNICAL FEATURES CARATTERISTICHE TECNICHE

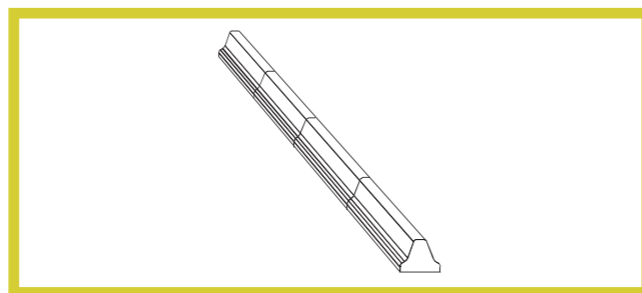
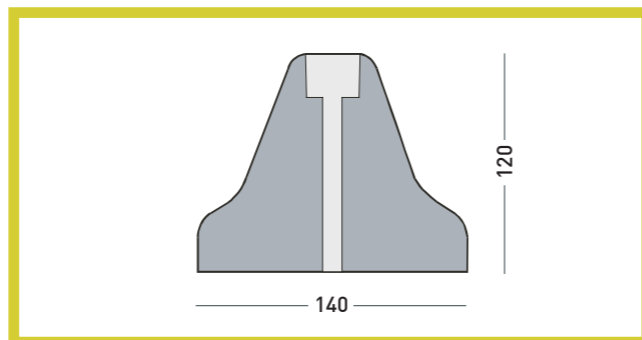
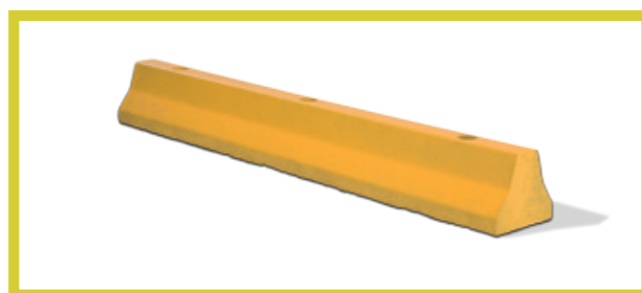

LENGHT/LUNGHEZZA	1000 mm
MAX WIDTH/LARGHEZZA MASSIMA	140 mm
HEIGHT/ALTEZZA	120 mm
WEIGHT/PESO	10,5 Kg +/- 10%

COLOURS/COLORI  
Natural black. Colours: various painted colours (non-toxic water paint) or mass coloured.

Nero naturale. Colori: verniciato (vernice ad acqua) oppure pigmentato in massa.



**INTENDEED USE**  
Temporary or permanent installation as lane dividers to direct traffic flow during roads work, emergencies, etc.

**APPLICAZIONI**  
Per separazione di corsie, aiuole, bypass, spazi viari, soluzioni temporanee di dissuasione, deviazioni di pronto intervento, delimitazioni di cantiere, ecc.



**ATTACHMENTS**  
1. Steel screw and screw anchor.  
2. Steel screw or threaded bar with chemical fixing.

**ACCESSORI A RICHIESTA**  
1. Viti in acciaio e tasselli a espansione.  
2. Viti in acciaio o barre filettate fissate con prodotti chimici.



**INSTALLATION**  
Line up the curbs and drill the pavement; put the screws anchor or the chemical fixing; set off the curb, and in case the flexible rubber delineator, the screws or the threaded bars; tighten them.

**POSA**  
Allineare i cordoli e forare la pavimentazione; posizionare il tassello o il collante; posizionare il cordolo, l'eventuale deflego e le viti/barre filettate; serrare la bulloneria di fissaggio.

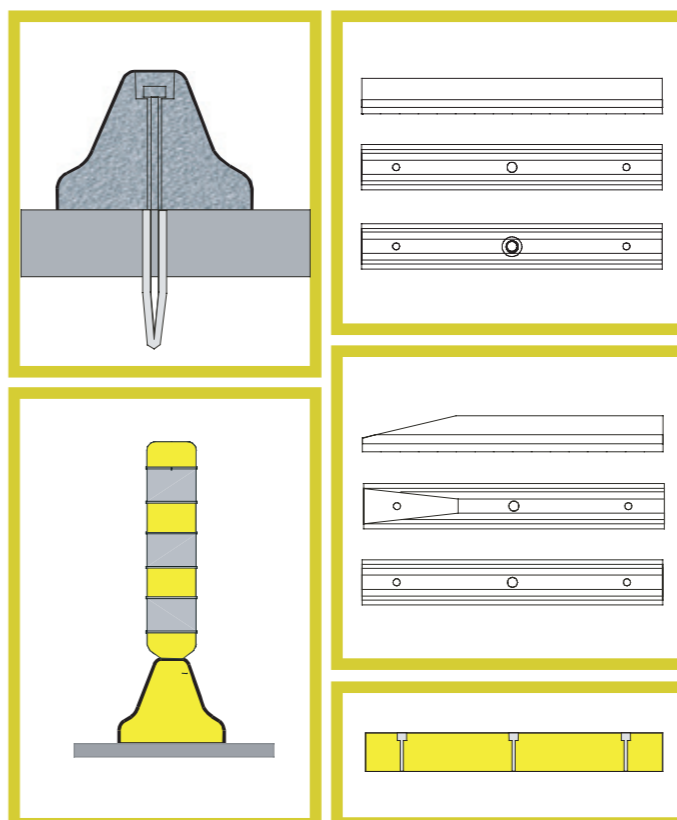

### CERTIFICATION CERTIFICAZIONI



CYCLE LANES  
PISTE CICLABILI



SCHOOLS  
SCUOLE



PUBLIC GARDENS  
GIARDINI PUBBLICI



FLOWERBEDS  
AIUOLE



RESTRICTED TRAFFIC ZONES  
AREE TRAFFICO LIMITATO



OUTDOOR AND MULTILEVEL PARKING  
PARCHEGGI SCOPERTI E MULTIPIANO



PLAYGROUND AREAS  
AREE GIOCO



PEDESTRIAN LINES  
CORSIE PEDONALI



DRIVEWAYS  
ACCESSO VIALETTI PRIVATI / PASSI CARRAI



RAILWAY STATIONS  
STAZIONI FERROVIARIE



BUS STATIONS  
STAZIONI AUTOBUS

### PLUS



ANTISHOK  
ANTITRAUMA



ECO-SUSTAINABLE  
ECO-SOSTENIBILI



EASY TO INSTALL  
FACILI DA INSTALLARE



CERTIFICATED  
CERTIFICATI



**RUBBER PRODUCTS FOR URBAN FURNITURE AND STREET APPLICATIONS**  
*PRODOTTI IN GOMMA PER LA VIABILITÀ STRADALE E L'ARREDO URBANO*



Rubber  
CITY

**CITY IS A RUBBER X PRODUCT**  
*CITY È UN PRODOTTO RUBBER X*



**INFO@RUBBERX.IT**  
**WWW.RUBBERX.IT**